

Audio System

without Navigation

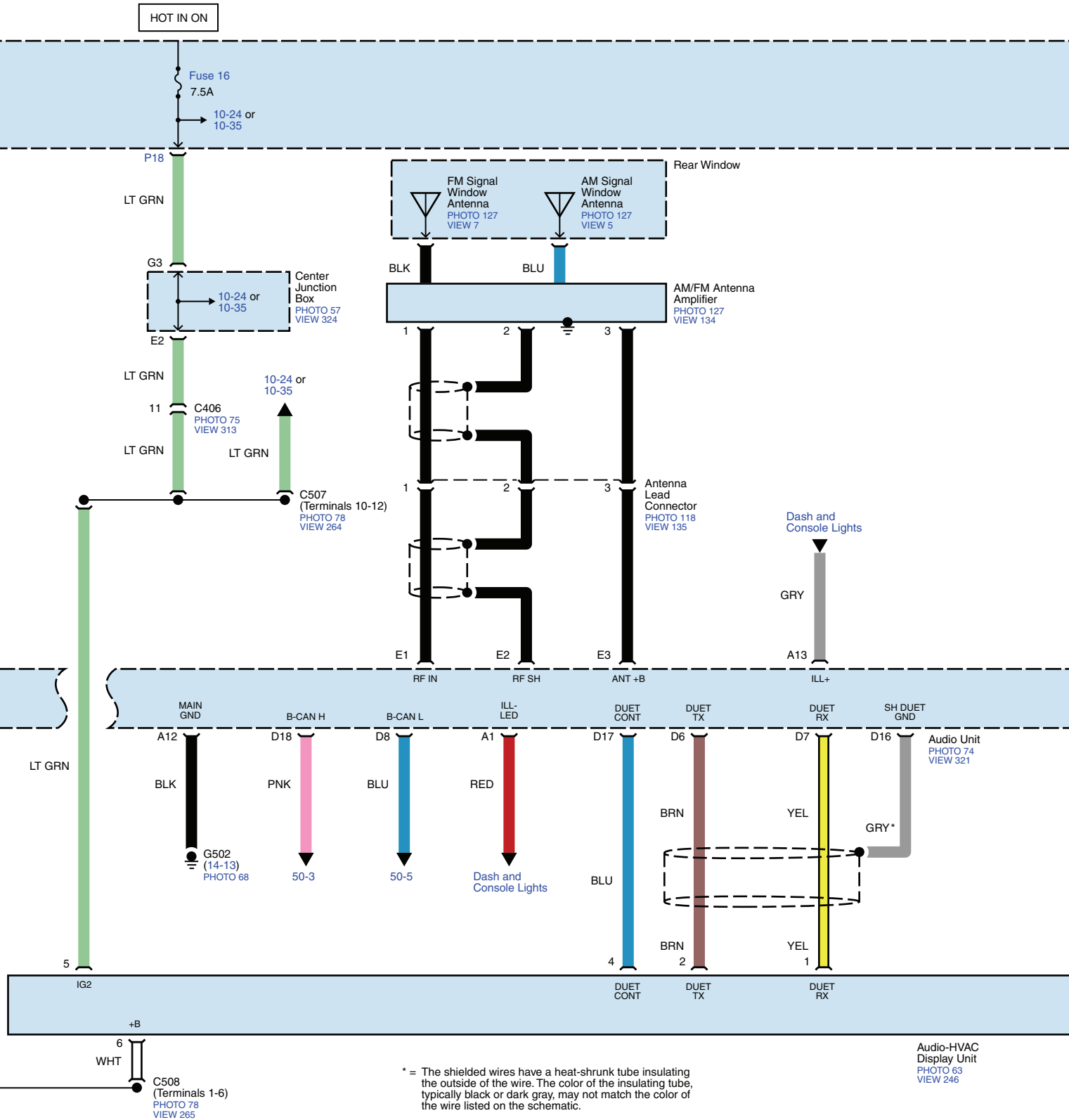

Audio System

without Navigation

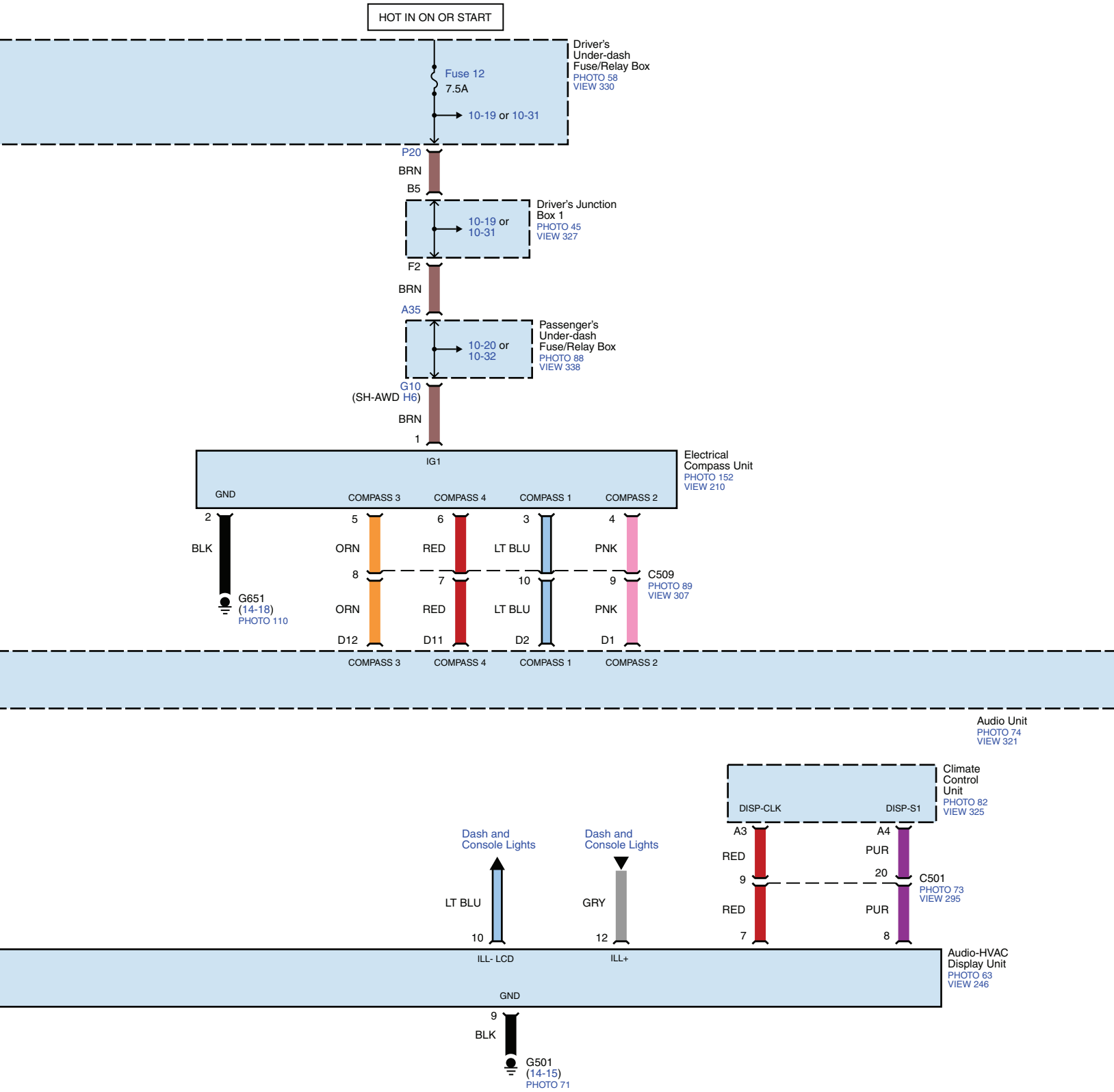

Audio System

without Navigation

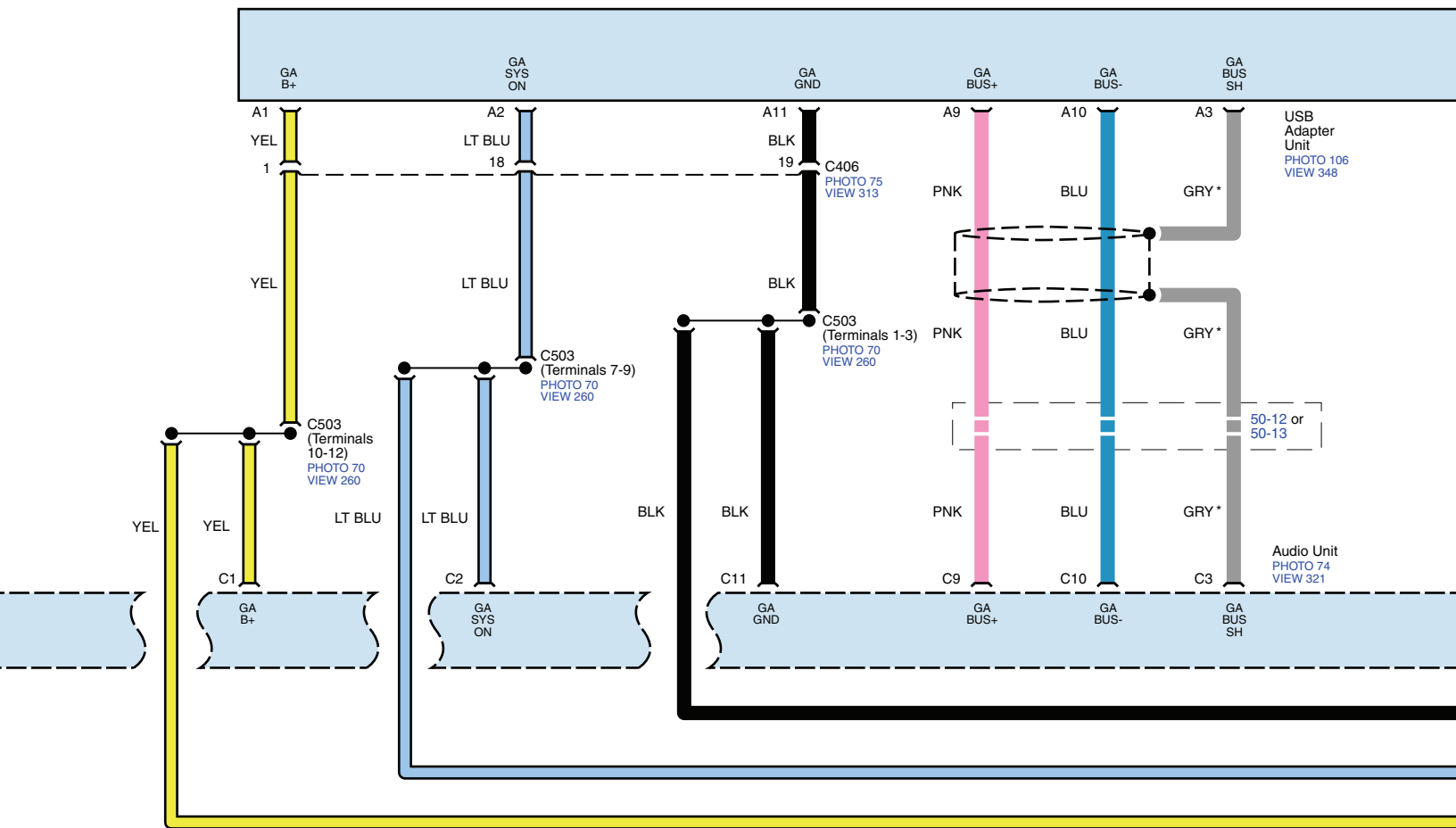

* = The shielded wires have a heat-shrunk tube insulating the outside of the wire. The color of the insulating tube, typically black or dark gray, may not match the color of the wire listed on the schematic.

Audio System

without Navigation

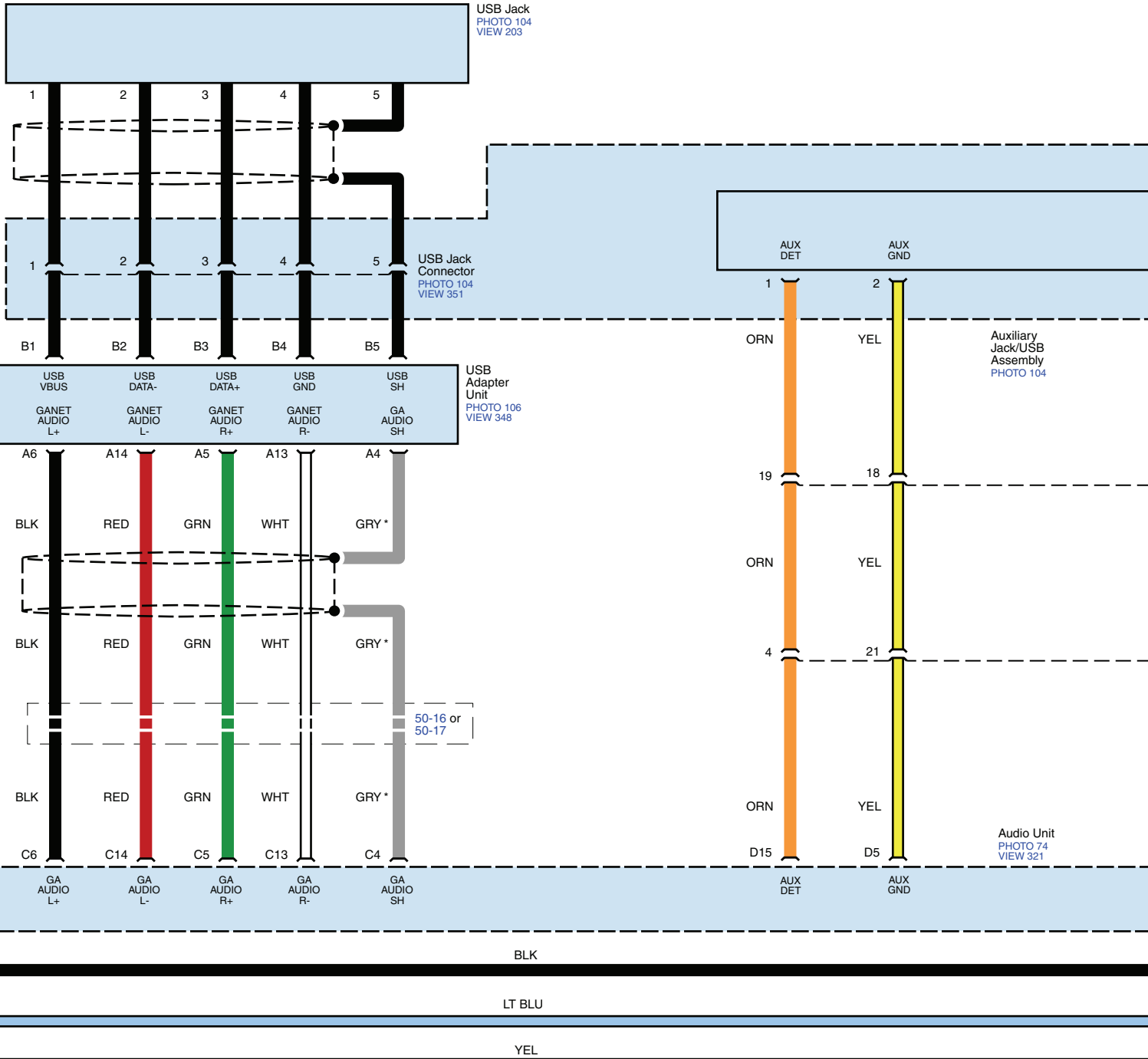

* = The shielded wires have a heat-shrunk tube insulating the outside of the wire. The color of the insulating tube, typically black or dark gray, may not match the color of the wire listed on the schematic.

Audio System

without Navigation

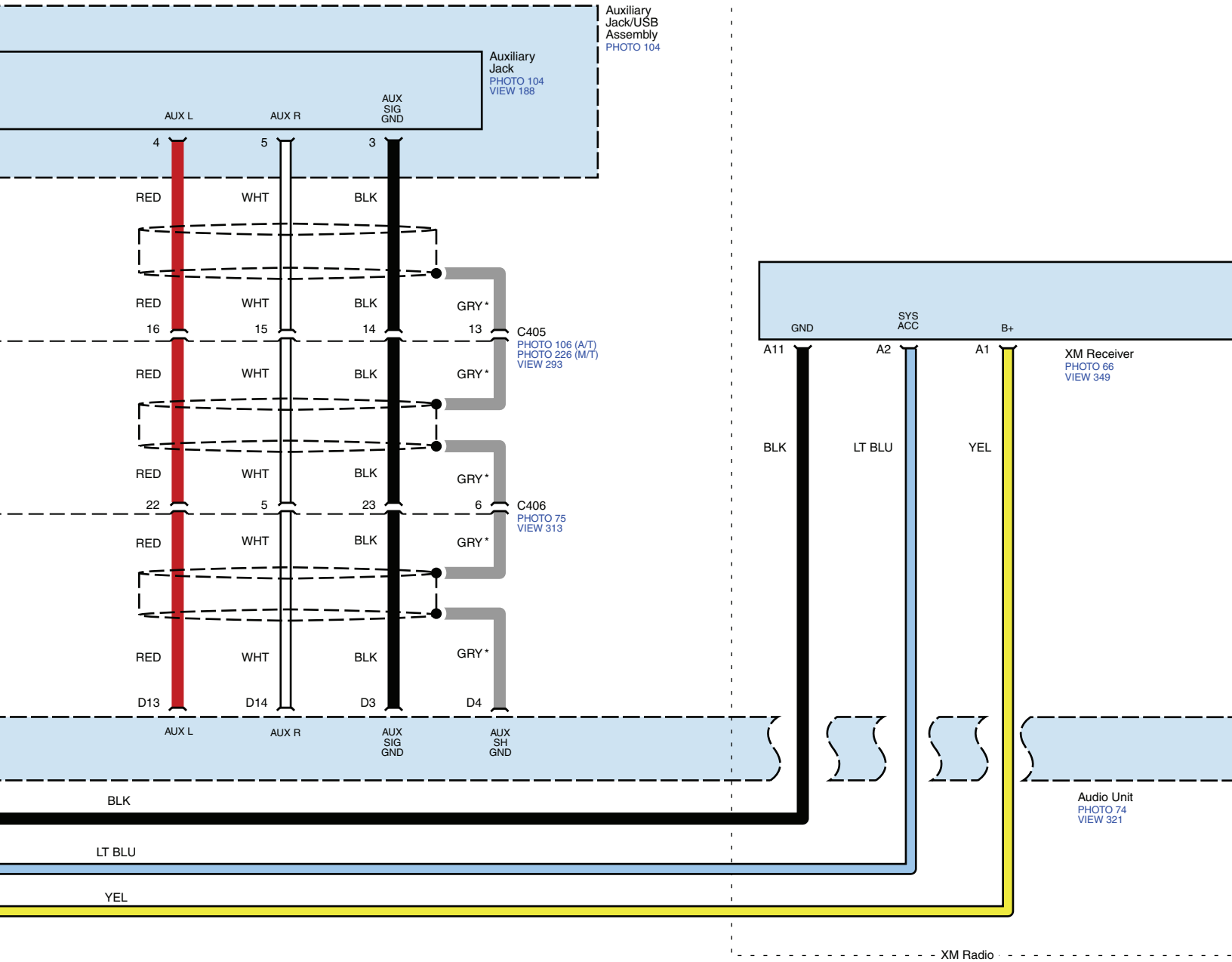

* = The shielded wires have a heat-shrunk tube insulating the outside of the wire. The color of the insulating tube, typically black or dark gray, may not match the color of the wire listed on the schematic.

Audio System

without Navigation

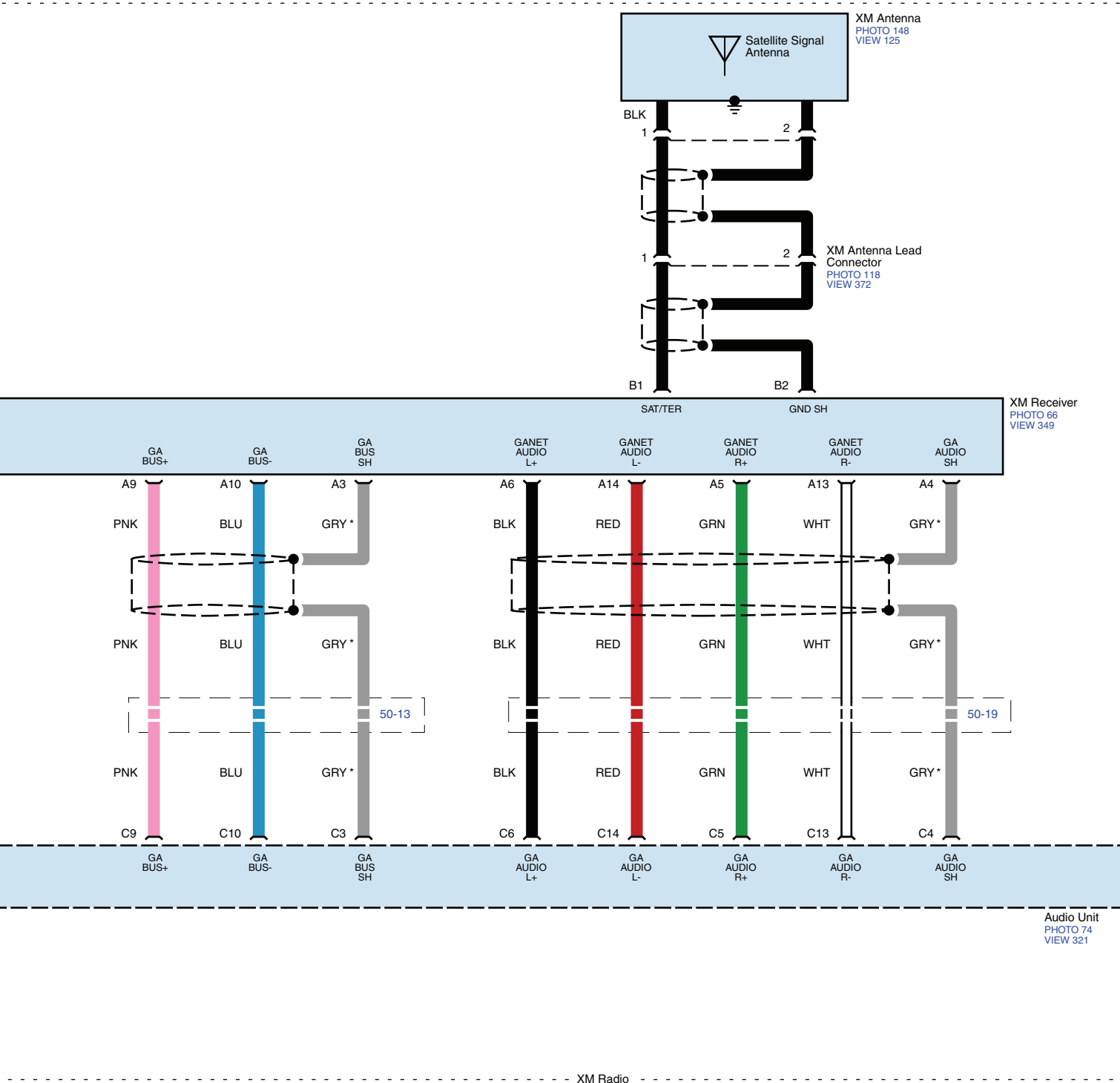

* = The shielded wires have a heat-shrunk tube insulating the outside of the wire. The color of the insulating tube, typically black or dark gray, may not match the color of the wire listed on the schematic.

Audio System

without Navigation

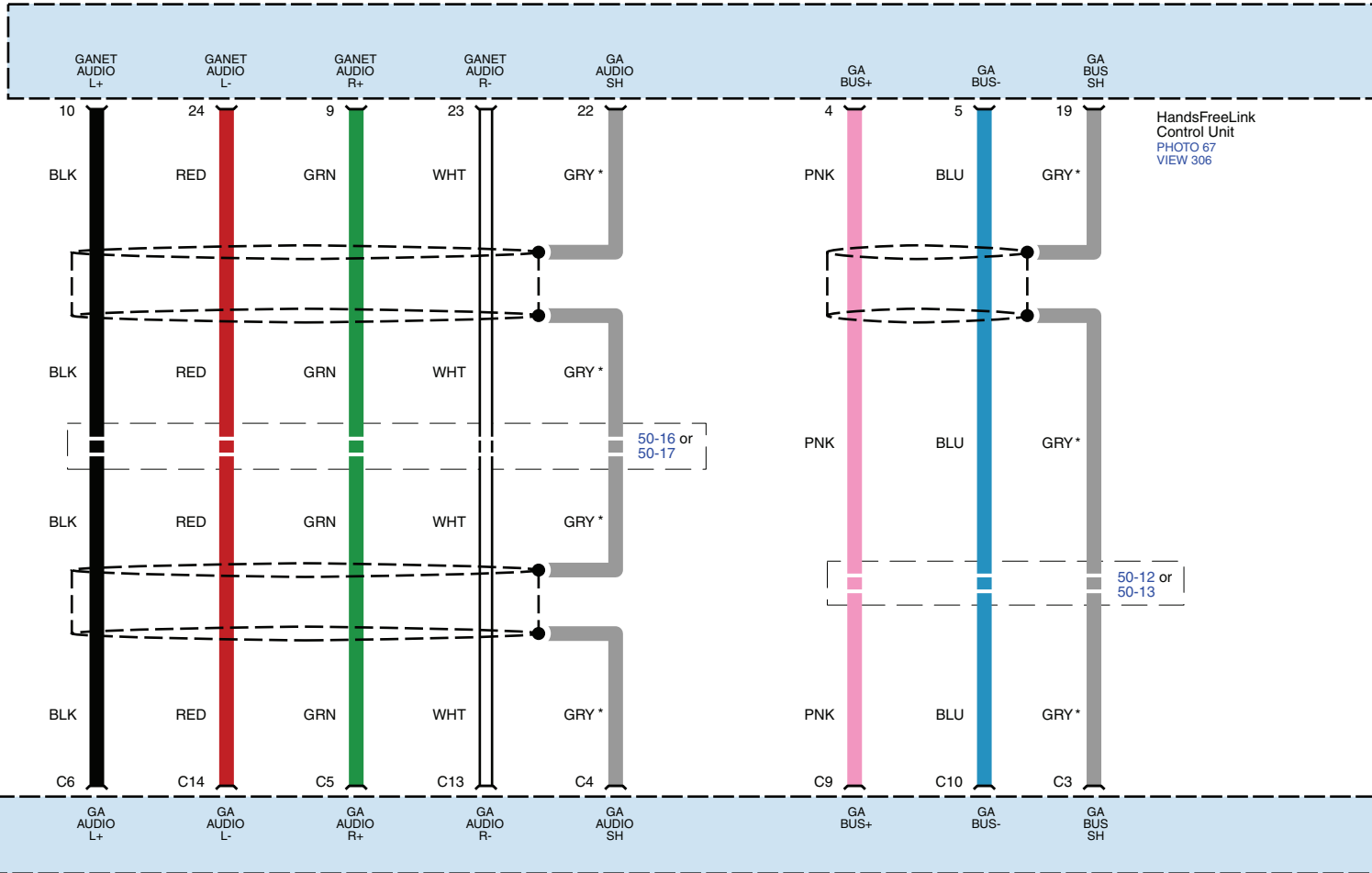

Audio Unit
PHOTO 74
VIEW 321

* = The shielded wires have a heat-shrunk tube insulating the outside of the wire. The color of the insulating tube, typically black or dark gray, may not match the color of the wire listed on the schematic.

Audio System

without Navigation

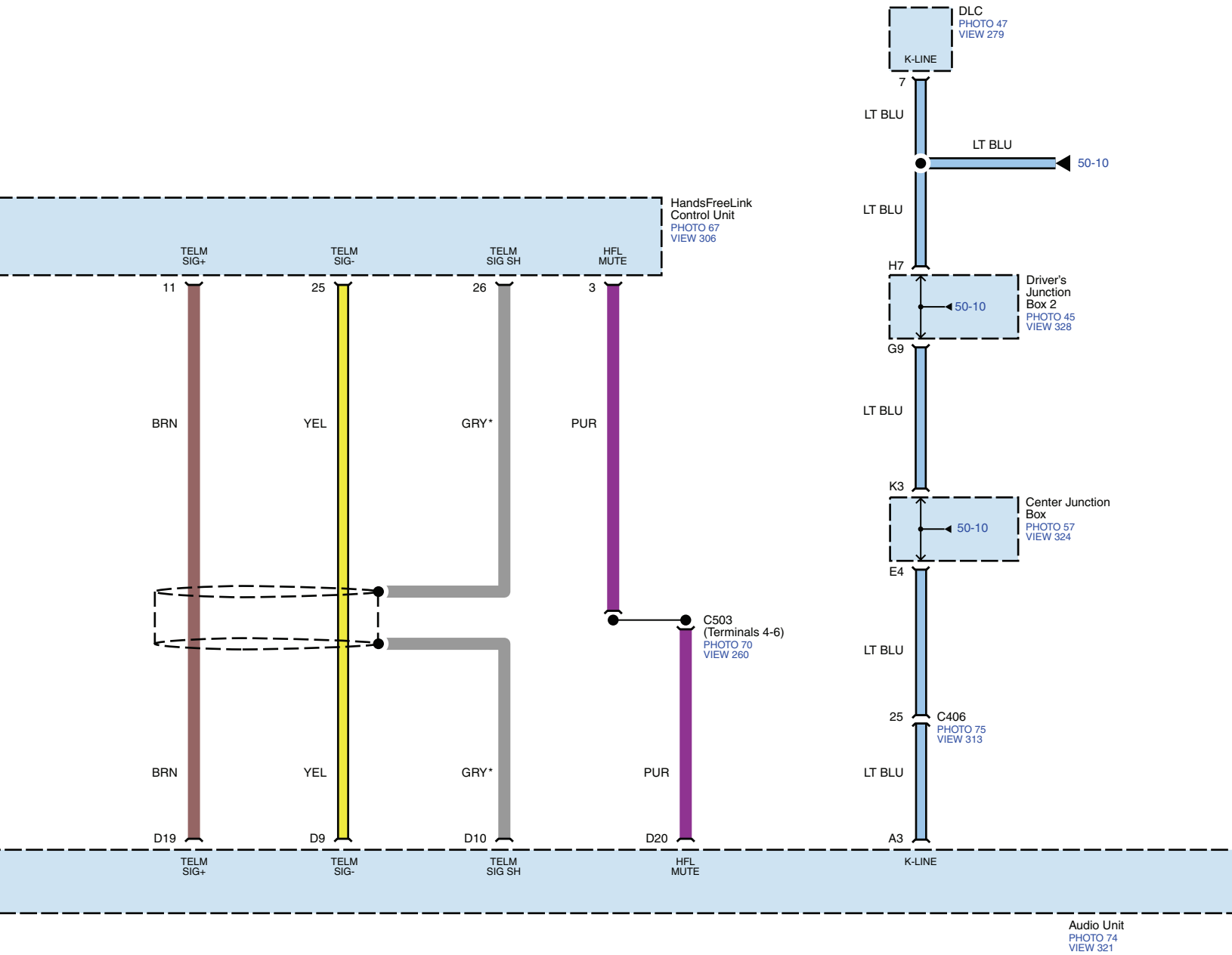

* = The shielded wires have a heat-shrunk tube insulating the outside of the wire. The color of the insulating tube, typically black or dark gray, may not match the color of the wire listed on the schematic.

Audio System

without Navigation

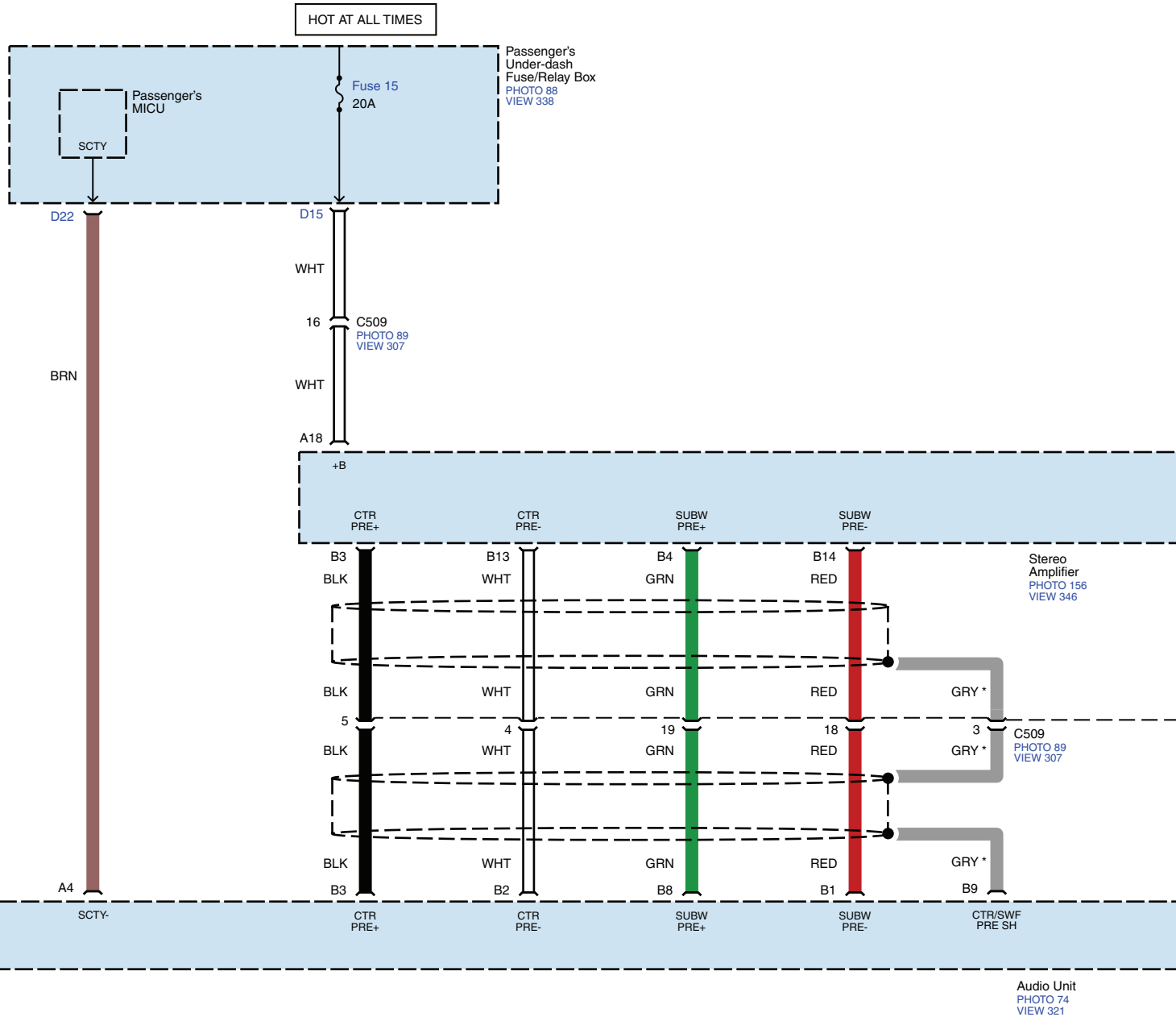

* = The shielded wires have a heat-shrunk tube insulating the outside of the wire. The color of the insulating tube, typically black or dark gray, may not match the color of the wire listed on the schematic.

Audio System

without Navigation

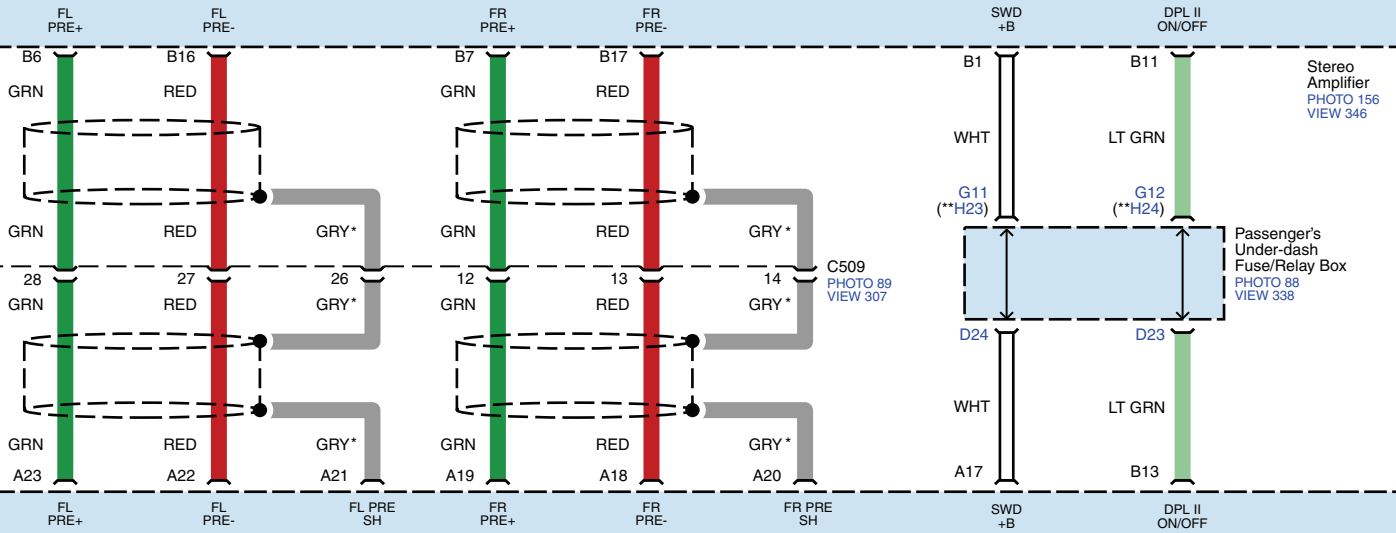

* = The shielded wires have a heat-shrunk tube insulating the outside of the wire. The color of the insulating tube, typically black or dark gray, may not match the color of the wire listed on the schematic.
 ** = SH-AWD

Audio System

without Navigation

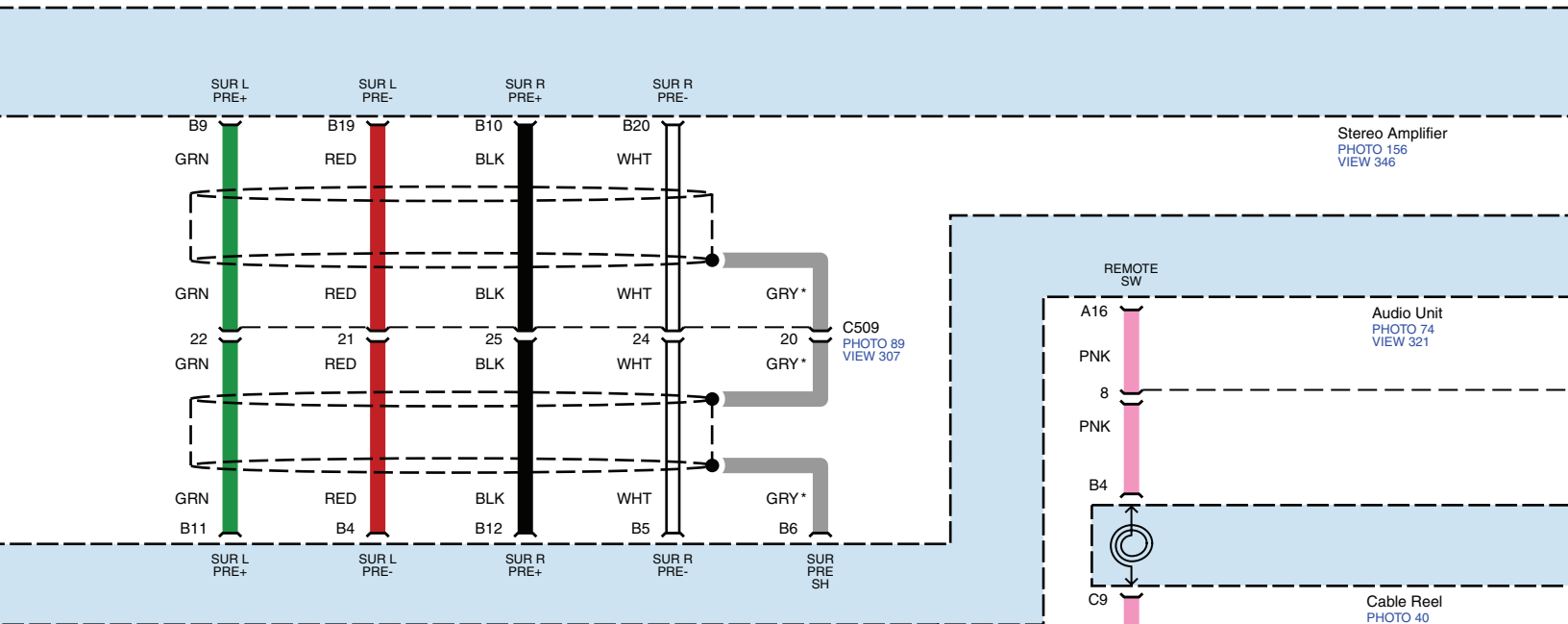

* = The shielded wires have a heat-shrunk tube insulating the outside of the wire. The color of the insulating tube, typically black or dark gray, may not match the color of the wire listed on the schematic.

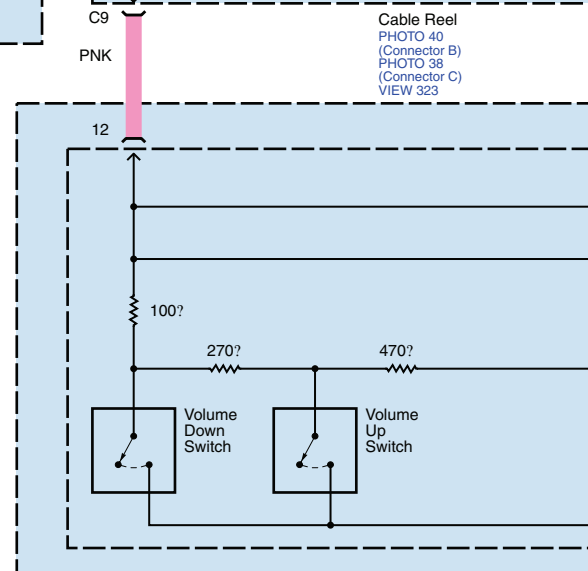
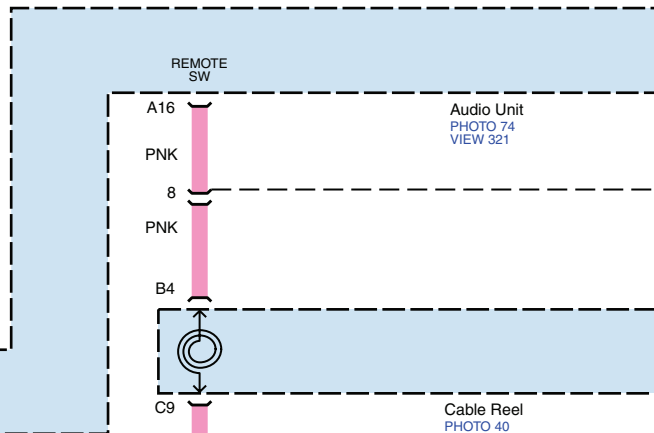

Steering Wheel

Audio System

without Navigation

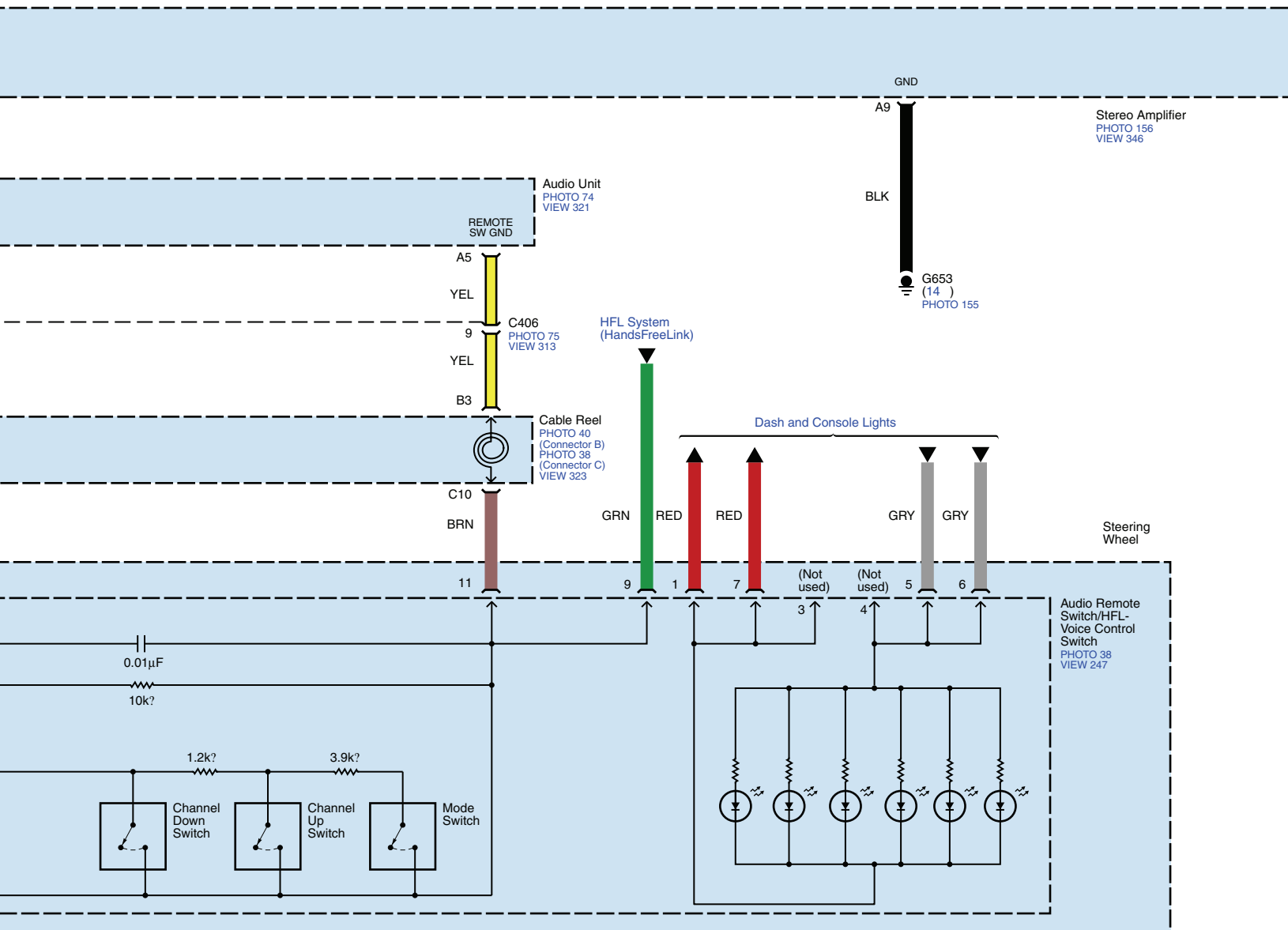

Audio System

without Navigation

* = Coupler Type 1
** = Coupler Type 2

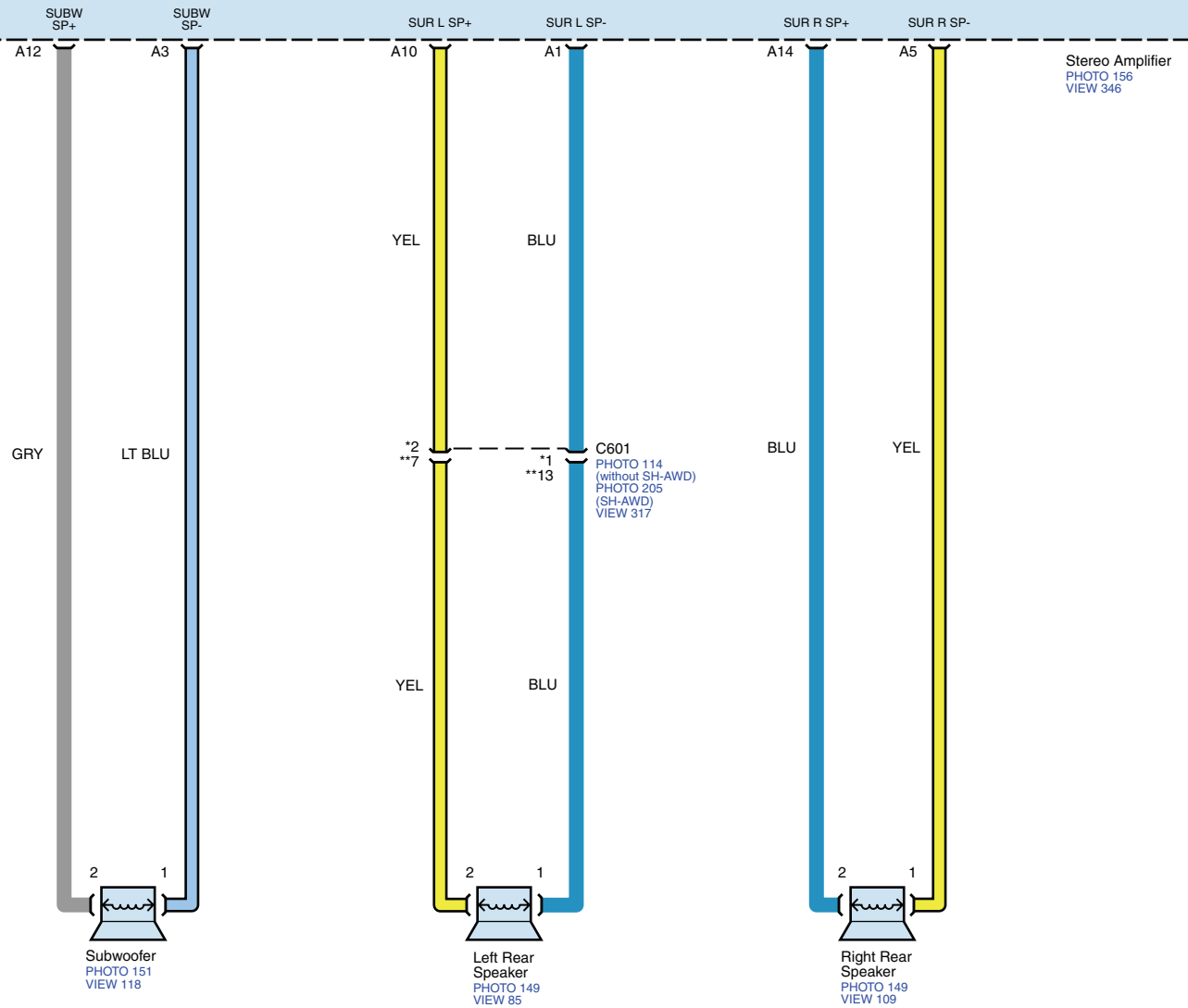

Audio System

without Navigation

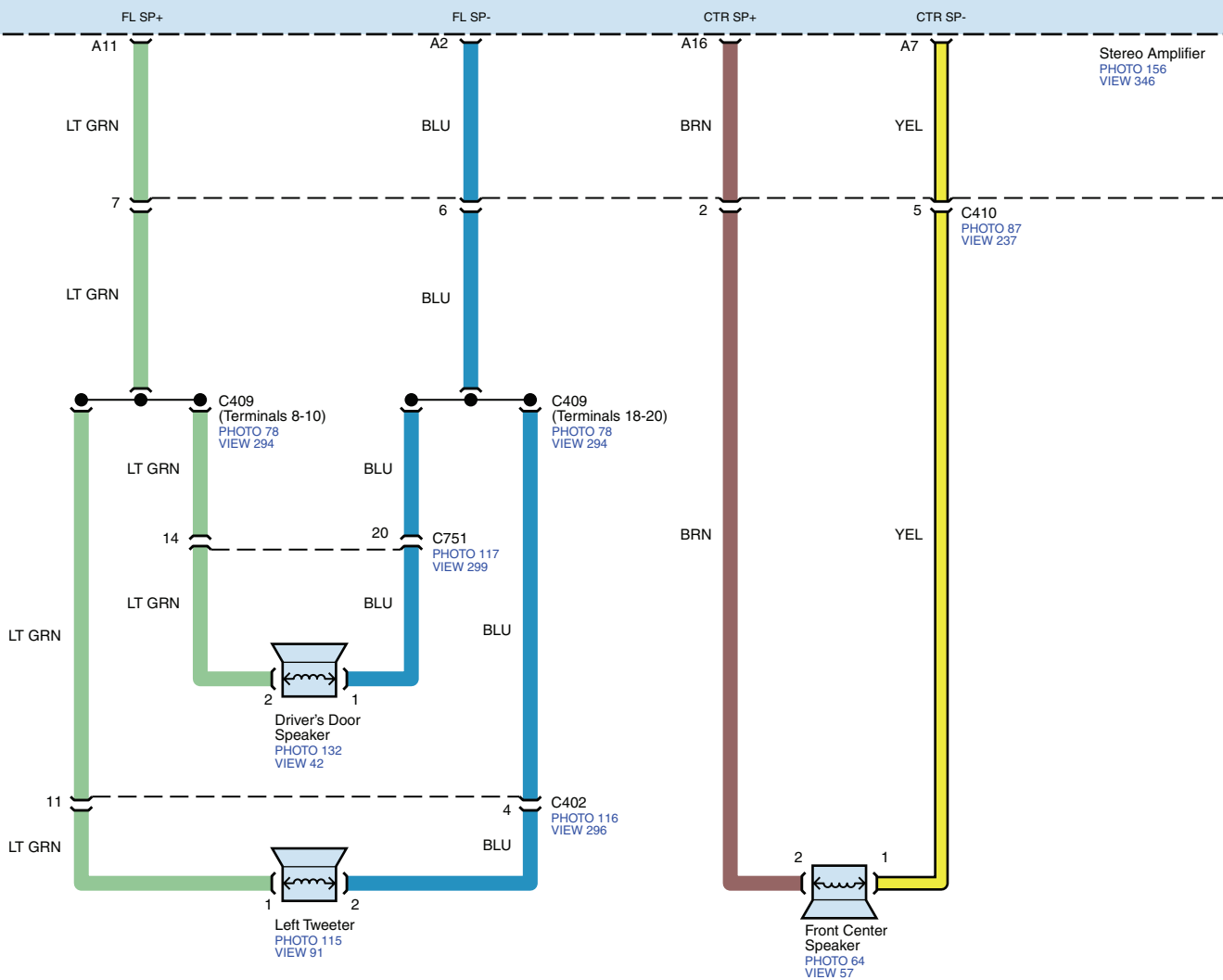

Audio System

without Navigation

